



**APPLICATION DEADLINE  
with Early-Bird Discount  
早鳥優惠截止報名日期  
28/8/2026**

**16-17/11/2026 • 香港 • Hong Kong**

**香港會議展覽中心 Hong Kong Convention & Exhibition Centre**

**Website: www.almac.hk**

**APPLICATION DEADLINE  
截止報名日期  
25/9/2026**

**Important Notice 重要事項**

- All information must be completed in English unless otherwise stated 除註明外，所有資料請以英文填寫
- The "Company Name" should be the same as appeared on the Business Registration Certificate and will be used for publicity and booth fascia 「公司名稱」必須與貴公司商業登記證上所列相同，並將用作宣傳及攤位之公司招牌
- The "Contact Details" will be published on the event website. You may as a result receive enquiries directly from interested buyers 「聯絡資料」將刊登於活動網站內，參展商可能會直接收到買家的電子諮詢郵件
- Hong Kong enterprises could consider applying for the BUD Fund, the cumulative funding ceiling per enterprise under the BUD Fund is HK\$7 million. Hong Kong enterprises seeking information about eligibility and the scope of funding can visit the website of the BUD Fund (www.bud.hkpc.org), or contact the Hong Kong Productivity Council, the Fund Implementer.  
香港中小企可考慮申請「BUD專項基金」資助，每間企業的最高累計資助上限為港幣七百萬元。如有興趣了解相關申請資格及資助範圍，可瀏覽「BUD專項基金」網站(www.bud.hkpc.org)；或與基金執行機構——香港生產力促進局聯絡。

## Part I 第一部份 Company Information 公司資料

1. Company Name (Eng):
- 公司名稱 (英文):
- Company Name (Chi):
- 公司名稱 (中文):

The "Company Name" should be the same as appeared on the Business Registration Certificate. 「公司名稱」應與商業登記證上所列之相同。

2. Address 地址:
3. Postal Code 郵編:
4. Country / Territory 國家 / 地區:

Contact information to be listed in the Exhibitor List on event website for receiving general inquiries 聯絡人資料將刊登於展會網站內參展商名單之聯絡資料

5. Company Tel No. 公司電話:
- Country Code 國家號碼      Area Code 區域字頭      Number 電話號碼
6. Company Fax No. 公司傳真:
7. E-mail 電子郵件:

Contact information for fair related matters only 負責有關展覽事宜之聯絡人資料

8. Contact Person 聯絡人 Mr. / Miss / Ms. 先生 / 小姐 / 女士:
9. Position 職位:
10. Direct Tel No. 直線電話:
11. E-mail 電子郵件:

Please make sure the email address you provided is a valid and frequently used email. The Organisers will communicate with your company via this email address only.  
請確保以上填寫的電子郵箱為常用及有效，主辦機構日後只會以電子郵件方式與貴公司聯繫。

12. Web Site 網址:
13. Business Registration No. 商業登記證號碼:

Organisers 主辦機構:

In association with 合作單位:

An event of:



## Part II 第二部份 Supplementary Information 補充資料

Please provide the information below to Ms. Crystal Cheung via email: crystal.ty.cheung@hktdc.org with this completed application form for publication on the event website

請把以下資料連同已填妥的此申請表電郵至 crystal.ty.cheung@hktdc.org 張芷瑩小姐收，以供活動網站展示之用。

1. Chinese and English company profiles (within 200 Chinese words and 100 English words, in MS Word format)  
中文及英文公司簡介 (中文200字內，英文100字內，並以 MS Word 文檔格式提交)
2. Company logo (Format: JPEG, Resolution: at least 300 dpi, File size: 5MB or above)  
公司商標 (格式：JPEG, 像素：最少300 dpi, 檔案大小：5MB以上)
3. Business Registration Certification Copy  
商業登記證副本

## Part III 第三部份 Exhibition Zone 參展區

Please "X" the preferred zone, 請在下列合適之空格內加上X號

Zone 展區	Business Nature of Exhibitors 參展商業務性質	Preferred Zone 首選展區	
Green Energy 綠色能源	<ul style="list-style-type: none"> <li>• Green energy consultancy 綠色能源顧問服務</li> <li>• Green energy infrastructure 綠色能源基礎設施</li> <li>• Green energy storage 綠色能源儲存</li> </ul>	<ul style="list-style-type: none"> <li>• Green finance service providers 綠色金融服務供應商</li> <li>• Green and renewable energy service providers 綠色及可再生能源服務供應商</li> <li>• Green port service providers 綠色港口服務供應商</li> </ul>	<input type="checkbox"/>
Logtech Salon Logtech 專區	<ul style="list-style-type: none"> <li>• AI, Big data analytics and cloud technology providers 人工智能、大數據及雲端科技供應</li> <li>• Cargo and fleet tracking and monitoring solution providers 貨物和運輸隊追蹤及監控解決方案供應商</li> <li>• E-commerce application and solution providers 電子商貿應用軟件及解決方案供應商</li> </ul>	<ul style="list-style-type: none"> <li>• E-commerce associations 電子商貿行業組織</li> <li>• Platform developers and marketing agencies 平台開發及營銷代理</li> <li>• IT and telecommunication service providers 資訊科技及電訊服務供應商</li> </ul>	<input type="checkbox"/>
Low-altitude Economy 低空經濟區	<ul style="list-style-type: none"> <li>• Drone service providers 無人機服務供應商</li> <li>• Drone technologies 無人機技術</li> </ul>	<ul style="list-style-type: none"> <li>• Drone training institutions / associations 無人機培訓機構 / 學院</li> <li>• Government and regulatory bodies 政府及監管機構</li> </ul>	<input type="checkbox"/>
Supply Chain Management and Logistics Services 供應鏈管理及物流服務	<ul style="list-style-type: none"> <li>• 3PLs 第三方物流服務供應商</li> <li>• Airlines 航空公司</li> <li>• Air cargo terminal operators 空運中心營運商</li> <li>• Cross-border delivery, express and postal service providers 跨國傳送、速遞及郵政服務供應商</li> <li>• Freight forwarders 貨物承運商</li> <li>• Logistics park/Bonded port operator 物流園/保稅港口營運商</li> </ul>	<ul style="list-style-type: none"> <li>• Railway operators 鐵路營運商</li> <li>• Supply chain management institutions / associations 供應鏈管理學院/行業組織</li> <li>• Supply chain management solution providers 供應鏈管理解決方案供應商</li> <li>• Supply chain finance and fintech service providers 供應鏈金融及金融科技平台服務商</li> <li>• Storage / Warehousing / Value-added service providers 倉庫/倉儲業務/增值服務供應商</li> </ul>	<input type="checkbox"/>
Maritime and Port Services 海運及港口服務	<ul style="list-style-type: none"> <li>• Container terminal operators 貨櫃碼頭營運商</li> <li>• Marine insurance providers 海事保險供應商</li> <li>• Maritime arbitration and legal service providers 海事仲裁及法律服務供應商</li> <li>• Port authorities 港口管理機構</li> <li>• Shipbuilding and repairing service providers 船舶建造及維修服務供應商</li> </ul>	<ul style="list-style-type: none"> <li>• Shipowners and ship management companies 船舶擁有人及管理公司</li> <li>• Shipping and maritime institutions / associations 航運及相關學院/行業組織</li> <li>• Shipping lines 班輪公司</li> <li>• Ship broking and chartering providers 船舶經紀及租賃供應商</li> <li>• Ship finance providers 船舶融資供應商</li> </ul>	<input type="checkbox"/>

NOTE: Final decision will be made at the discretion of the Organisers. 主辦單位保留最終決定權。

## Part IV 第四部份 Option of Participation 參展方法

Exhibition Format 參展形式	No. of Booth(s) 攤位數量	Participation Fee 參展費	Total Participation Fee 參展費合計
6 sq.m. Premium Booth 6 平方米特級展位 (3m x 2m)		HK\$24,255 / US\$3,110 (per booth 每展位計) <b>Early Bird Discount (5% off)</b> 早鳥優惠 (九五折) <b>HK\$23,045 / US\$2,955</b> (per booth 每展位計)	HK\$ / US\$
4 sq.m. Start-up Booth 4 平方米初創企業展台 (2m x 2m) (Relevant start-ups with less than 3 years of establishment 只適用於成立3年以內及符合相關業務的初創企業)		HK\$8,820 / US\$1,135 (per booth 每展位計) <b>Early Bird Discount (5% off)</b> 早鳥優惠 (九五折) <b>HK\$8,380 / US\$1,080</b> (per booth 每展位計)	HK\$ / US\$
Custom-built Participation <sup>1</sup> (min 18 sq.m.) 特裝參展 (最少18平方米)		HK\$730 / US\$95 (per sq.m. 每平方米計) <b>Early Bird Discount (5% off)</b> 早鳥優惠 (九五折) <b>HK\$695 / US\$90</b> (per sq.m. 每平方米計)	HK\$ / US\$
Booth A [For Low-altitude Economy Zone Only] (Approximate 9 sq.m.) 展位A [只適用於低空經濟區] (約9平方米)		HK\$36,380 / US\$ 4,665 (per booth 每展位計) <b>Early Bird Discount (10% off)</b> 早鳥優惠 (九折) <b>HK\$32,745 / US\$ 4,200</b> (per booth 每展位計)	HK\$ / US\$
Booth B [For Low-altitude Economy Zone Only] (Approximate 6 sq.m.) 展位B [只適用於低空經濟區] (約6平方米)		HK\$24,255 / US\$ 3,110 (per booth 每展位計) <b>Early Bird Discount (10% off)</b> 早鳥優惠 (九折) <b>HK\$21,830 / US\$ 2,800</b> (per booth 每展位計)	HK\$ / US\$

### Remarks 附註：

- For Custom-built participation, only carpeted space rental is included in the above listed fee. Construction costs and any other additional costs should be borne by exhibitor. 特裝參展價目僅包含已鋪設地氈之空地租金，參展商須自行承擔施工費用和任何其他額外費用。
- Booth allocation will be on a ballottment basis. 展位位置將以抽籤結果決定。
- The organiser reserves the right to review all applications. All requests are subject to availability and the Organiser's discretion. 主辦機構有權審批所有參展商之申請。申請會否被接納視乎供應及主辦機構決定。
- The Organiser reserves the right to change the booth assignment, configuration, facilities and / or amend the floorplan at any time without giving notice to the exhibitor. 主辦機構保留權利隨時更改展位位置、規格、設施及展覽會的圖則，毋須通知參展商。
- US\$ Participation Fee is only applicable to exhibitors from overseas and Mainland China. 美元參展費只適用於海外及內地參展商。
- Early bird application deadline 早鳥優惠截止報名日期 28/8/2026

## Part V 第五部份

## Booth Layouts and Facilities 攤位規格及設施 (For Reference Only 只供參考)

### 6 sq.m. Premium Booth 6 平方米特級展位

Perspective



Top View

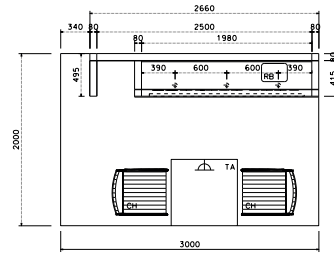

- 1 Company Fascia 公司名牌
- 1 Panel Display 展示板
- 1 System Square Table 方形桌子
- 2 Chairs 椅子

Elevation

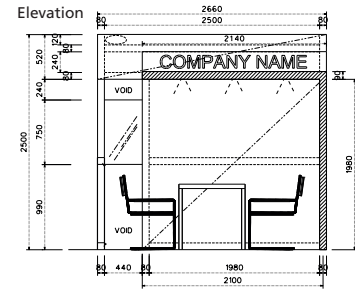

- 3 LED Track Lights LED路軌燈
- 1 Power Socket (500 watt) 電源插座 (500瓦特)
- 1 Rubbish Bin 垃圾桶

### 4 sq.m. Start-up Booth 4 平方米初創企業展台

Perspective



Top View

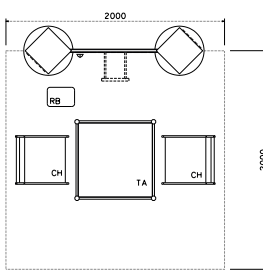

- 1 Company Fascia 公司名牌
- 1 Panel Display 展示板
- 1 System Square Table 方形桌子
- 2 Chairs 椅子

Elevation

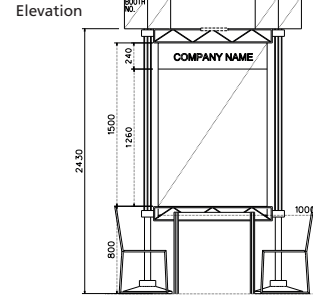

- 1 LED Gilbert Lamp LED長臂鋁通燈
- 1 Power Socket (500 watt) 電源插座 (500瓦特)
- 1 Rubbish Bin 垃圾桶

## Applicable to Low-altitude Economy Zone Only 僅適用於低空經濟區

### Booth A (Approximate 9 sq.m.) 展位 A (約9平方米)

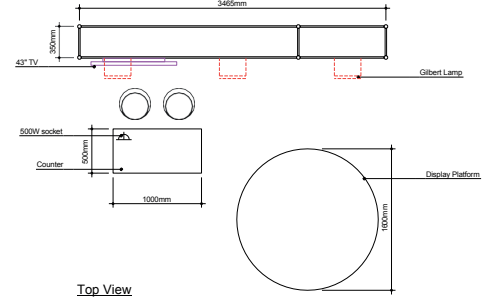
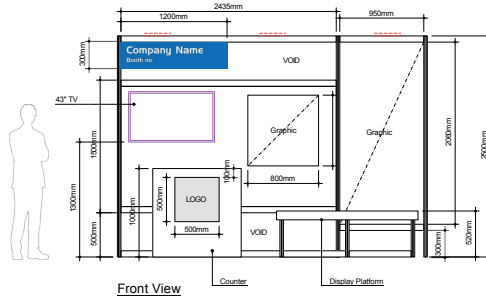

- 1 Company Fascia 公司名牌
- 2 Company Logo 公司商標 (500mmLx500mmW)
- 1 System Made Counter with Company Logo 櫃檯 (連公司商標)
- 2 High Chairs 吧椅
- 1 Display Platform 展示平台
- 3 Gilbert Lamps 畫燈
- 1 500W Socket 電源插座(500瓦特)
- 1 Rubbish Bin 垃圾桶
- 1 (950mmW x 2060 mmH) Poster & 1 (800mmW x 800mmH) Poster (output file provided by client)  
1張(950毫米寬×2060毫米高)海報及1張(800毫米寬×800毫米高)海報 (輸出檔案由展商提供)  
(\*TV is not included in the package, additional quotation can be provided upon request)  
(\*電視不包括在套餐內,如有需要可額外報價)

### Booth B (Approximate 6 sq.m.) 展位 B (約6平方米)

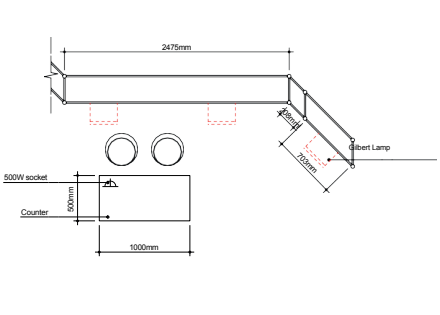
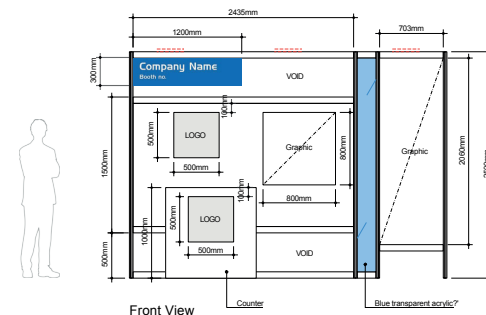

- 1 Company Fascia 公司名牌
- 2 Company Logo 公司商標 (500mmLx500mmW)
- 1 System Made Counter with Company Logo 櫃檯 (連公司商標)
- 2 High Chairs 吧椅
- 3 Gilbert Lamps 畫燈
- 1 500W Socket 電源插座(500瓦特)
- 1 Rubbish Bin 垃圾桶
- 1 (703mmW x 2060 mmH) Poster & 1 (800mmW x 800mmH) Poster (output file provided by client)  
1張(703毫米寬×2060毫米高)海報及1張(800毫米寬×800毫米高)海報 (輸出檔案由展商提供)

## Part VI 第六部份 Business Matching 商貿配對

Please provide below information to facilitate arrangement of business matching meetings. (You may provide multiple answers. Please add "√" in the suitable box(es)) 請提供以下資料，以供安排商貿配對會議之用。(可選擇多項，請在適當空格內加"√")

Nature of Business 業務性質		Our Company 本公司	Partner Looking for 尋找之 商貿夥伴
<b>Shippers 貨主</b>			
Distributor 分銷商			
e-tailer/ E-Commerce Platform Operator 網上零售商/ 網上零售平台營運商			
Export Agent 出口代理			
Exporter 出口商			
Import Agent 進口代理			
Importer 進口商			
Manufacturer / Supplier 製造商 / 供應商			
Retailer 零售商			
Wholesaler 批發商			
<b>Green Energy 綠色能源</b>			
Green energy consultancy 綠色能源顧問服務			
Green energy infrastructure 綠色能源基礎設施			
Green energy storage 綠色能源儲存			
Green finance service providers 綠色金融服務供應商			
Green and renewable energy service providers 綠色及可再生能源服務供應商			
Green port service providers 綠色港口服務供應商			
<b>Logtech and E-Commerce Support 物流科技及電子商貿支援</b>			
Cross-border delivery, express and postal service providers 跨國傳送、速遞及郵政服務供應商			
Cargo and fleet tracking and monitoring solution providers 貨物和運輸隊追蹤及監控解決方案供應商			
Drone service providers 無人機服務供應商			
Drone technologies 無人機技術			
Drone training institutions / associations 無人機培訓機構 / 學院			
E-commerce application and solution providers 電子商貿應用軟件及解決方案供應商			
Government and regulatory bodies 政府及監管機構			
Platform developers and marketing agencies 平台開發商及營銷代理			
Big data analytics and cloud technology providers 大數據及雲端科技供應商			
IT and telecommunication service providers 資訊科技及電訊服務供應商			
<b>Supply Chain Management and Logistics Services 供應鏈管理及物流服務</b>			
3PL 第三方物流服務供應商			
Supply chain management solution providers 供應鏈管理解決方案供應商			
Supply chain finance and fintech service providers 供應鏈金融及金融科技平台服務商			
Supply chain management institutions / associations 供應鏈管理學院/行業組織			
Freight forwarders 貨物承運商			
Storage / Warehousing / Value-added service providers 倉庫/倉儲業務/增值服務供應商			
Airlines 航空公司			
Air cargo terminal operators 空運中心營運商			
Railway operators 鐵路營運商			
Logistics park / Bonded port operators 物流園 / 保稅港口營運商			
<b>Maritime and Port Services Provider 海運及港口服務</b>			
Shipowners and ship management companies 船舶擁有人及管理公司			
Shipping lines 班輪公司			
Ship broking and chartering providers 船舶經紀及租賃供應商			
Container terminal operators 貨櫃碼頭營運商			
Marine insurance providers 海事保險供應商			
Maritime arbitration and legal service providers 海事仲裁及法律服務供應商			
Port authority 港口管理機構			
Ship finance providers 船舶融資供應商			
Shipbuilding and repairing service providers 船舶建造及維修服務供應商			
Shipping and maritime institutions / associations 航運及相關學院/行業組織			
<b>Others (Please specify) 其他 (請說明)</b>			
<b>Region of Business 業務地區</b>			
Current coverage 現有覆蓋範圍			
Regions interested to explore 有興趣探索的地區			
<b>Industry Sector(s) of Expertise 專門之行業類別</b>			
Consumer Electronics 消費電子產品	Electronic / Electrical Components & Accessories 電子/電器零件及配件	Fine Jewellery 首飾	Food and Beverage 食品及飲料
Footwear 鞋類	Garments 成衣	Giftware & Premiums 禮品及贈品	Household Appliances 家用電器
Toys and Games 玩具及遊戲	Watches & Clocks 鐘錶	Other (please specify): 其他 (請說明):	

Remarks 附註：

Participation in business matching meetings is voluntary. While HKTDC will at its best effort identify suitable companies for business matching, under any circumstances that the companies identified are unable to attend the arranged meetings, or do not match your needs as specified in your application, or that the HKTDC is unable to identify suitable companies for business matching, HKTDC shall not be obliged to make any refund arrangement.

參與商貿配對會議屬自願性質。香港貿發局將盡所能為參展商選擇合適公司進行商貿配對，如在任何情況下獲配對之公司未能出席會議，或未能符合貴司申請表格中指明需要相配合的業務性質，或香港貿發局未能找到合適的公司與貴司進行商貿配對，香港貿發局沒有義務退回任何款項。

## Part VII 第七部份 Application Procedure & Payment Methods 參展方法及付款方式

Please return the completed application form, together with the required payment and supplementary info in Part II: Merchandise Trade and Innovation Department, Hong Kong Trade Development Council, 38/F, Office Tower, Convention Plaza, 1 Harbour Road, Wan Chai, Hong Kong. Attn: Ms. Crystal Cheung

請將填妥之申請表格連同參展費用及第二部份所需的資料交回：

香港灣仔港灣道一號會展廣場辦公大樓三十八樓 香港貿易發展局商品貿易及創新部 張芷瑩小姐收

Whether an application will be accepted depends on a number of factors, including space availability. In case of over subscription of space, applicants will be placed on a waiting list and will be notified accordingly. Applicants on the waiting list will be prioritized according to the dates of the applications. Allocation of exhibition space and booth location will be at the discretion of the Organiser.

申請獲接納與否取決於多種因素，包括可供使用空間的情況。在超額申請使用攤位的情況下，申請人會被列入輪候名單並據此接獲通知。在輪候名單上的申請人會按遞交申請日期順序處理。主辦機構有權分配展覽面積及展位位置。

**APPLICATION DEADLINE: 25 Sept 2026 截止申請日期：2026年9月25日**

### Payment Method For Hong Kong Exhibitors 香港參展商付款適用

Please submit a crossed cheque payable to "HONG KONG TRADE DEVELOPMENT COUNCIL" together with the completed application form and information

請交回填妥之格並附上劃線支票，支票抬頭請註明“香港貿易發展局”。

### Payment Method For Overseas and Mainland Exhibitors 海外及內地參展商付款適用

Remittance should be paid by telegraphic transfer (T/T) to "HONG KONG TRADE DEVELOPMENT COUNCIL" USD Account Number 004-002-7-642925 with The Hongkong & Shanghai Banking Corporation Limited, 1 Queen's Road Central, Hong Kong. (All banking charges, if any, are to be borne by the applicant.) **Swift Code: HSBCHKHKKH**

如電匯付款請把費用直接存入本局之美金賬戶，賬戶資料如下：

美金開戶銀行：香港上海滙豐銀行 (地址：香港中環皇后大道中1號)

戶口名稱“香港貿易發展局”(有關匯款之銀行收費需由申請人負責)

美金賬戶號碼：004-002-7-642925

Swift Code: HSBCHKHKKH

## Part VIII 第八部份 Company Stamp and Signature 公司印鑑及簽名

We (Name of Company)

本公司 (公司名稱) \_\_\_\_\_

hereby apply to participate in the exhibition of The Asian Logistics, Maritime and Aviation Conference (ALMAC) 2026.

We understand that the participation fee is non-refundable and agree to be bound by the provisions of all documents forming part of the application form.

We hereby declare that the information given in the application form is true and correct to the best of our knowledge.

We understand that any false or misleading information given by us to the HKTDC will lead to the rejection of our right to participate in the exhibition. We understand that above information will be included into the HKTDC's databank and the HKTDC can make use of our information for trade promotion purposes.

謹此申請參加亞洲物流航運及空運會議2026之展覽。我們明白參展費用不設退款，並同意接受構成申請表一部份的所有文件的條文約束。

我們謹此聲明，就我們所知，申請表上所填寫的資料均屬真實正確。我們明白向香港貿發局提供任何錯誤或有具誤導性質的資料將導致我們參加展覽的權利遭拒絕受理。我們明白以上資料將納入香港貿發局的資料庫內，而香港貿發局可使用我們的資料作貿易推廣用途。

Name: Mr. / Miss / Ms.

負責人姓名 (正楷) : \_\_\_\_\_

Position :

職位 : \_\_\_\_\_

Company Stamp & Authorised Signature:

公司印鑑及負責人簽名 : \_\_\_\_\_

Date :

日期 : \_\_\_\_\_

# CONDITIONS OF PARTICIPATION

## 1. DEFINITIONS

In these Conditions of Participation and the Application Form, save as the context otherwise requires:

"Applicant" means the company named in Part I of the Application Form.

"Application" means the application by the Applicant to participate in the Exhibition, made by submitting the Application Form together with all necessary payments to the Council.

"Application Form" means the application form to which these conditions are annexed.

"Booth" means a booth in the Exhibition which the Council licenses the Participant to use for the duration of the Exhibition.

"Conditions" means these Conditions of Participation as amended by the Council from time to time.

"Council" means the Hong Kong Trade Development Council.

"Delegate(s)" means the individual(s) named in Part I of the Application Form who is/are nominated by the Participant to attend and represent it at the Exhibition.

"Executive Director" means the Executive Director appointed by the Council from time to time;

"Exhibition" means the exhibition named in the Application Form.

"Hong Kong" means the Hong Kong Special Administrative Region of the People's Republic of China.

"Optional Participation Expenses" means the amount payable by each Participant for additional facilities and services such as shipment of samples, extra stand facilities and interpreters, provided by the Council at its request, which amount shall be determined by the Council.

"Participant" means the Applicant after its Application has been accepted by the Council.

"Participation Fee" means the amount payable by the Participant to the Council for the right to participate in the Exhibition, as specified in Section L of the Application Form.

Services described in Section I of the Application Form and which the Council agrees to accept for exhibiting at the Booth during the Exhibition.

"Publicity Material" means all and any promotional gifts, catalogues, pamphlets, advertising and publicity material whatsoever which the Participant wishes to display, distribute or use at or for the purpose of the Exhibition.

"Related Companies" in respect of the Applicant or Participant means its holding companies, subsidiaries and subsidiaries of its holding companies.

## 2. ACCEPTANCE

(a) The Applicant must be a Hong Kong entity with a valid Hong Kong business registration certificate with substantial operations in Hong Kong.

(b) The Executive Director, on behalf of the Council, may in his/her absolute discretion accept or reject the Application without providing any reasons therefor.

(c) The Applicant represents and warrants that none of its Related Companies, associates, or persons or companies that are effectively under its control has applied to participate in the Exhibition. The Council has an absolute discretion to reject the Application or withdraw its acceptance of the Application if the Applicant shall have breached this warranty and representation.

(d) For the avoidance of doubt, neither any acknowledgement of the receipt of the Application Form nor any request for payment made or issued by the Council shall by any means constitute acceptance of the Applicant's application.

## 3. PAYMENT

(a) Upon submission of its Application, the Applicant shall pay to the Council such amounts and in such manner as set out in Part IV of the Application Form.

(b) If the Applicant has requested for additional facilities and services in accordance with Part IV of the Application Form, it shall further pay to the Council upon submission of its written request for such services and facilities:

i. such amount as the Council in its sole discretion considers appropriate as deposit for the Optional Participation Expenses if such request is made prior to the commencement of the Exhibition; and

ii. the full amount of the Optional Participation Expenses if such request is made on-the-spot during the Exhibition (see paragraph 3(e) below).

(c) If the Application is rejected, the Council will within 30 days of the date of notice of rejection refund to the Applicant all amounts received by it from the Applicant pursuant to paragraphs 3(a) and 3(b) above without interest.

(d) When the Application is accepted by the Council, the Applicant will become a Participant.

(e) The Participant may request for additional facilities and services on-the-spot during the Exhibition but all fees in relation to such request must be paid in full by the Delegates before the additional facilities and services are provided by the Council or its contractor. All such requests must be made in writing to the Council directly.

(f) i. If the Participant requests the Council or its recommended travel agent (the "Agent") to reserve hotel accommodation for its Delegates, the Participant shall pay to the Council or the Agent such amount as the Council or the Agent may deem appropriate as deposit which shall be at least equal to the first night's accommodation charges at the hotel. The Council or the Agent will endeavour to reserve accommodation in its name for the Delegates and on reserving the accommodation, pay to the hotel the amount which it has received from the Participant.

ii. The Delegates shall settle with the hotel directly the balance in full of all charges incurred by them at the hotel when they check out from the hotel.

iii. The Participant shall indemnify the Council against all liabilities incurred by its Delegates in connection with the hotel and shall on demand pay to the Council immediately all amounts claimed by the hotel against the Council in respect thereof.

(g) i. In no case will action be taken by the Council until and unless the respective amounts payable pursuant to this paragraph 3 and Part IV of the Application Form have been paid in full to the Council.

ii. If the Council requests any additional amount to be paid by the Applicant/Participant, no further action will be taken by the

Council until and unless such additional amount has been paid in full to it.

(h) All payments by the Participant to the Council shall be made promptly without any deduction, set-off or counterclaim.

(i) All requests by the Participant for any additional facilities and services are subject to the Council's ability to procure such facilities and services. The Council does not warrant or represent that it will be able to procure any such facilities or services. If the Council is unable to procure the requested facilities or services, it will as soon as practicable inform the Participant and will refund to the Participant any amount received by it in relation to such requested facilities or services.

(j) The Council accepts no liabilities and gives no warranties or representations in respect of the quality, standard, fitness for any purpose, timing of the provision or otherwise of any of the facilities or services provided by the Council at the Participant's request.

(k) The Council shall have discretion to deduct from the deposit paid for Optional Participation Expenses under paragraph 3(b) against any losses or expenses incurred by it by reason of the failure of the Participant to comply with the Conditions or supplying false or misleading information to the Council.

(l) The Participant shall reimburse the Council of all Optional Participation Expenses paid on its behalf. If, in the opinion of the Council, the deposit paid for Optional Participation Expenses under paragraph 3(b) is or will likely be insufficient to pay for all the actual expenses to be incurred by the Council, the Council may at any time request an additional amount to be paid by the Participant which, in the opinion of the Council, is sufficient to pay for such actual expenses. The Participant shall, within 5 days of receiving such request, pay the requested amount to the Council. No further action will be taken by the Council until and unless such additional amount has been paid in full.

## 4. SETTLEMENT OF ACCOUNTS

(a) The Council will issue a statement of account to the Participant setting out the actual cost of the provision of any additional facilities and services, the amount of deposit paid for Optional Participation Expenses and the balance due to the Council (where the actual cost exceeds the deposit) or the amount of refund to the Participant (where the actual cost is less than the deposit).

(b) The Participant shall pay to the Council the amount due to the Council as shown on the statement of account within 14 days of its receipt. A surcharge of 2% per month will be imposed on any outstanding amounts after the due date for payment.

(d) The Council reserves the right to offset any balance to be refunded to the Applicant/Participant against any outstanding liabilities due by the latter to the Council in relation to their participation in the Council's other activities.

(e) No interest will be payable by the Council in respect of any refund amounts to the Applicant/Participant.

## 5. BOOTH

(a) The Council has the sole and absolute discretion in allotting the area in the Exhibition for the positioning or construction of Booths and determining the location of such Booths. All decisions to such effect shall be final and no request for change will be entertained.

(b) The Council will in its absolute discretion allocate 1 or more than 1 Booth(s) to the Participant by way of a licence for the exhibition of its Products. The Participant shall have no claims whatsoever against the Council in respect of any loss or damage suffered by the Participant and/or its officers, representatives, agents and employees (including without limitation any loss or damage arising from any liability incurred to third party) howsoever caused by the location, construction or material of the Booth allocated to it unless such loss or damage involves death or personal injury resulting from the negligence of the Council.

(c) The Participant shall not assign its licence to occupy the Booth or part with the possession of or permit any third party to occupy the Booth or any part thereof regardless of the relationship between the third party and the Participant.

(d) In the interests of maintaining a high standard of presentation at the Exhibition and a favourable image of Hong Kong as a whole, the Project Manager may in his/her absolute discretion require the Participant to withdraw or alter in any way the presentation of any Products or Publicity Material.

(e) Publicity Materials of any Participant may only be distributed from the Participant's own Booth. No advertising, demonstration or canvassing for business may be carried out anywhere else within the Exhibition. No exhibits or advertising signs shall be placed outside the confines of the Participant's Booth.

(f) All Products, Booth materials/Publicity Materials and the like of the Participant shall be removed by the relevant Participant immediately after the closing of the Exhibition according to the arrangements and within the time limits specified by the Council.

Any Products or Booth materials/Publicity Materials and the like of the Participant left behind at the Exhibition shall be deemed abandoned and shall be disposed of by the Council at the expense of the Participant concerned. All proceeds (if any) of such disposal shall be retained by the Council and the Council shall not be obliged to account the proceeds to the relevant Participant.

(g) No alteration or addition to the Booth or its fittings may be made by or on behalf of the Participant without the prior permission of the Project Manager.

(h) The removal and disposal of crates and booth fittings or materials are not covered by the Participation Fee and are subject to an additional charge based on the charges or such other sum as the Council may reasonably determine.

(i) The Participant must not obstruct or cause to be obstructed any entrances to or passage to or passage ways in the Exhibition.

(j) No Booth or exhibits shall be dismantled or removed before the official closing time of the Exhibition on the last day of Exhibition unless special permission has been given by the Council.

## 6. PARTICIPATION IN THE EXHIBITION

(a) The Participant must be represented at the Exhibition by at least 1 Delegate.

(b) Any Delegate nominated to represent the Participant at the Exhibition must be a senior executive of the Participant.

(c) The Participant shall ensure that :-

i. at least one Delegate shall be in attendance at its Booth at all times when the Exhibition is open to visitors;

ii. each of its Delegates shall be fully conversant with the Products and shall be duly authorised to negotiate and conclude contracts for the sale of the Products;

iii. its Delegates shall comply with the Conditions and with all directions which the Project Manager may from time to time give in connection with any matter pertaining to the Exhibition.

(d) The Council reserves the right in its absolute discretion and without giving any reasons to require the Participant to replace any of its Delegates forthwith.

(e) The Participant shall use its best endeavours to uphold the reputation of the Council and to promote the success of the Exhibition.

## 7. EXHIBITS

(a) The Council shall have an absolute discretion to accept or reject any of the Exhibitor's exhibits for exhibiting in Hong Kong Pavilion without providing any reason therefor.

(b) The Exhibitor warrants that (i) the exhibits and the packaging, and (ii) all information, statements, photographs and illustration provided for publication of Hong Kong Pavilion's publicity materials thereof do not in any way whatsoever violate any third party rights including without limitation trademarks, copyrights, designs, names and patents whether registered or otherwise.

(c) The Exhibitor undertakes not to display anything which is unlawful, in breach of any person's intellectual property, harmful, threatening, violent, offensive, defamatory, libelous, scandalous, seditious, vulgar, obscene, indecent, invasive of another's privacy, hateful, racially, ethnically or otherwise objectionable.

(d) The Exhibitor warrants that (i) the exhibits and the packaging, and (ii) all information, statements, photographs and illustration provided for publication of Hong Kong Pavilion's publicity materials thereof do not in any way whatsoever violate any applicable laws, rules and regulations of the importing countries.

(e) The Exhibitor shall be solely responsible for and shall settle all expenses and liabilities incurred by it in relation to its exhibition in Hong Kong Pavilion, including without limitation all shipping and transportation charges, customs duties, handling charges and other costs and expenses arising from the shipment or any other mode of transportation of the exhibits in connection with the Exhibition Zone.

## 8. BUSINESS PRACTICES

(a) The Participant warrants and agrees that it will conduct itself and carry out its business in the Exhibition according to the ethical business practices. The Council may provide the guidelines regarding such ethical business practices to be observed by the Participant from time to time.

(b) The Participant agrees that it will immediately withdraw any products or publicity materials, or stop promoting any products or services in any particular manner, which in the absolute discretion of the Project Manager, is inconsistent with ethical business practices, or may affect the image of Hong Kong or the Exhibition, upon notice of the Project Manager.

(c) The Participant agrees that it will be responsible for the repair, replacement or full refund of any products sold at the Exhibition if the product is returned to the Participant within 30 days from the date of sale. Any such request for repair, replacement or refund shall be processed expeditiously by the Participant, and in any event not longer than 30 days from the date of return.

## 9. PUBLICITY

The Council will arrange for such publicity for the Exhibition as it shall in its absolute discretion deem fit. No Participant, Delegate or other officer, representative, agent or employee of the Participant shall give or cause to be given any interview, public announcement, press statement or any other publicity whatsoever in relation to the Exhibition.

## 10. INFORMATION

(a) During the Exhibition the Delegate shall provide the Council with such information as to the business results of the Participant in the Exhibition as the Project Manager may from time to time request. Such information will not be divulged to third parties without the Participant's approval, save in relation to collective figures in respect of all or a majority of the persons or companies participating in the Exhibition.

(b) At the conclusion of the Exhibition the Delegates shall complete questionnaires on the activities performed and the business carried out by the Participant during the Exhibition for the information of and further action by the Council.

## 11. TERMINATION OF RIGHT TO PARTICIPATE

(a) Without prejudice to the Council's other rights and remedies, the Council has the right to terminate forthwith by notice the Participant's right to participate in the Exhibition on or following the occurrence of any of the following events:

i. if the Participant or any of its Delegates, officers, representatives, agents or employees commits a breach of any of the Conditions;

ii. if the Participant, being a body corporate, enters into liquidation whether compulsorily or voluntarily or compounds with its creditors or has a receiver appointed over all or any part of its assets or if the Participant, being a sole proprietorship or partnership, becomes or one of its members becomes bankrupt or insolvent or enters into any arrangements with its creditors;

iii. if the Executive Director in his/her absolute discretion decides that such right shall be terminated;

(b) In the event that a Participant's right to participate in the Exhibition is terminated under clause 11(a)i or 11(a)ii of the Conditions, the Participant shall have no claim for refund of any monies paid to the Council.

(c) The Participant's right to participate in the Exhibition shall automatically terminate in the event that all its Delegates are refused entry visa or entry permit to the country or place where the Exhibition shall be held by any competent authorities.

(d) In the event that the Participant's right to participate in the Exhibition is terminated, any expenses incurred by the Council for and on behalf of the Participant prior to such termination and all other expenses reasonably incurred by the Council as a consequence of such termination shall be paid on demand by the Participant to the Council.

(e) The Council reserves the right to terminate the Exhibitor's right to participate in any future Exhibition if the Exhibitor is found to have committed any act including but not limited to failing to respect intellectual property rights of any other party, non-compliance with product safety, environmental laws and/or any other act which, in the sole opinion of the Council, might damage the reputation and/or image of Hong Kong, its industries, the Expo and/or the Council or if the Executive Director in his/her absolute discretion decides that such right shall be terminated.

## **12. POSTPONEMENT AND CANCELLATION**

The Council reserves the right to change the date(s) of the Exhibition to other date(s) (including but not limited to postponing to later date(s)) as the Council deems fit, or cancel, alter in character or mode, reduce in scale, shorten or extend the duration of the Exhibition at any time without incurring any liability whatsoever to the Participant due to circumstances beyond the Council's control including but not limited to acts of God, war, health concerns (such as outbreaks of the Severe Acute Respiratory Syndrome, bird flu or other health threats), fear of terrorist attack, riots, demonstrations, travel restrictions, curfew, epidemic, embargo, civil unrest, legal proceedings, industrial disputes of whatever nature, government regulations, the lack of or refusal to grant any government or third party approvals, permits, consents or licences, major disruption of transport system, system malfunctions or failure of telecommunications or other electronic communications that make it in the opinion of the Council impossible or impractical or undesirable for the Council to hold the Exhibition as initially planned. The Participant shall have no claim against the Council or its agents or representatives, whether for loss or damage, or return of all or part of any money paid by the Participant in respect of any postponement, cancellation, alternation, reduction, shortening or extension made in accordance with this provision.

## **13. EXCLUSION OF LIABILITY**

The Council shall not be liable for any loss, damage or personal injury howsoever suffered by or caused to the Participant or its Delegates, officers, representatives, agents, employees or any third party, or its Products or other property in the course of or in relation to the Exhibition, unless such loss, damage or personal injury shall be caused by any breach by the Council or its employees of the Conditions. For the avoidance of doubt, any death or personal injury caused by or resulting from the acts of God, war, health concerns (such as the outbreak of the Severe Acute Respiratory Syndrome), threats of terrorist attack, riots, demonstrations, civil disturbances, inevitable accident or any other cause not within control of the Council shall not be regarded as the negligence of the Council or its employees.

(b) The Council assumes no responsibilities for any introduction or transaction made between the Participant and any third party during or as a result of the Exhibition.

(c) The Participant shall be responsible for effecting all insurance coverage necessary in connection with its participation in the Exhibition including but not limited to insurance in respect of the Products, its other property and its Delegates (including travel and medical insurance).

(d) The Participant undertakes to indemnify and at all times hereafter to keep indemnified the Council from and against all liabilities, actions, proceedings, claims, damages, costs and expenses whatsoever which it may suffer or incur by reason of or in relation to any act, omission or default by the Participant or its Delegates, officers, representatives, agents and employees in the course of or in relation to the Exhibition.

## **14. CONFIDENTIAL INFORMATION**

The Participant shall not disclose or permit to be disclosed to any person or otherwise make use of or permit to be made use of any information relating to the business or affairs of the Council or other participants in the Exhibition which has been acquired by reason of the Participant's participation in the Exhibition.

## **15. WAIVER**

No failure or delay by the Council in exercising or enforcing any right or power hereunder shall operate or be construed or operated as a waiver thereof. No waiver of any breach shall be construed as a waiver of any continuing or subsequent breach.

## **16. NOTICE**

(a) Every notice or demand shall be in writing but may be given or made by post or email.

(b) Every notice or demand to be given by the Council may be sent to the address of the Participant stated in its Application Form. Every notice to be given by the Participant to the Council shall be sent to the office of the Council at 38th Floor, Office Tower, Convention Plaza, 1 Harbour Road, Wan Chai, Hong Kong.

(c) Every notice or demand shall be deemed to have been received in the case of an email, at the time of dispatch, and in the case of a letter three days after the posting of the same by prepaid post.

## **17. GENERAL**

(a) Nothing in the Application Form or the Conditions shall create or be deemed to create a partnership or the relationship of principal and agent or employer and employee between the Council and the Participant.

(b) The Application Form and the Conditions embody and set out the entire agreement and understanding of the parties and supersede all prior oral or written agreements, understandings or arrangements between the Council and the Applicant relating to the Exhibition.

(c) The Council reserves the right to alter and amend any of these Conditions and to issue additional rules and regulations (including but not limited to the participants' manual) at any time it considers necessary for the orderly operation of the Exhibition. The amended Conditions and the additional rules and regulations shall be sent to the Participant and become effective immediately. The Participant will be deemed to have notice of

the same and have accepted the amended Conditions and the additional rules and regulations. The Participant acknowledges that the Council shall have the right to interpret these Conditions, additional rules and regulations together any amendments thereof. All interpretations of these Conditions, any additional rules and regulations, and any amendments thereof by the Council shall be final and binding on the Participants.

## **18. GOVERNING LAW**

The Application Form and the Conditions shall be governed by and construed in all respects in accordance with the laws of Hong Kong and all the parties agree to submit to the non-exclusive jurisdiction of the Hong Kong court.